

Work and conservation of energy

1) A 0.75 kg mass is fired by a spring across a 2 m rough surface ($\mu_k = 0.67$). It then slides up an incline to some max height, slides back down and may or may not collide again with the spring. The spring constant is $K = 500 \text{ N/m}$. The mass is initially compressed against the spring a distance of 30 cm.

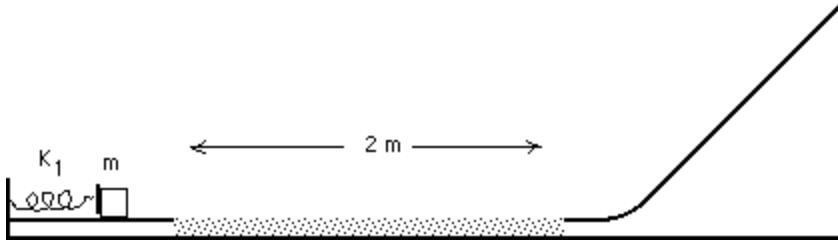

a) What % of the initial kinetic energy is lost on the first pass through friction?

b) how high does the mass climb up the incline on the first run, what potential energy is this

c) after sliding back down does the mass make it back to the spring.

d) if your answer to c) was yes, how far does the mass compress the spring upon colliding with it. How much work did the spring do against the mass this time?

e) where does the mass finally come to rest and what direction was it moving when it stopped

ans: a) 43.8 % b) 1.72 m, 12.6 J c) yes d) 10.6 cm, 2.8 J e) 0.569 m, to the right

2) A mass of 1.5 kg with an initial constant velocity curves up inside a smooth circular arc and comes to rest on top of a shelf with $\mu_k = 0.7$ Find:

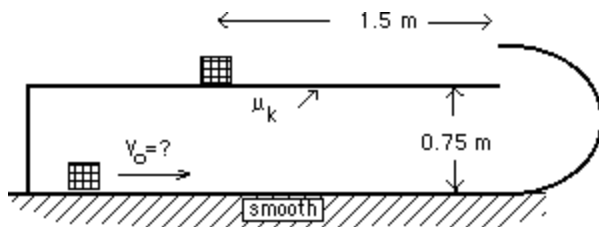

a) the initial velocity of the mass, do this without using the mass

b) what velocity did the mass have just as it exited the circular arc, do this without using the mass

c) how much work did friction do in stopping the mass.

ans: a) 5.94 m/s b) 4.53 m/s c) 15.43 J

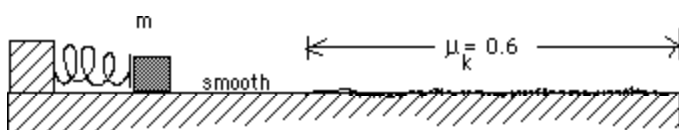

3) A mass $m = 0.5 \text{ kg}$ is fired from a spring that is compressed $X_c = 10 \text{ cm}$. The mass then encounters the rough surface of coefficient of friction $= 0.6$. The mass comes to rest after moving a distance of 1m

into the rough surface. Find:

a) if point "A" is the compressed mass and "B" is the mass at rest after sliding thru friction apply conservation of energy once to determine the spring constant K .

b) the work done by friction in stopping the mass.

c) the velocity of the mass before entering the rough area.

d) the potential energy stored in the spring.

e) once in the rough area how long until it stops

ans : a) 588 N/m b) 2.94 J c) 3.43 m/s d) 2.94 J e) 0.583 s

4) A mass at the top of a rough incline is released from rest and slides down to the bottom. find

$m = 1 \text{ kg}$, $\theta = 30^\circ$, $\mu_k = 0.2$

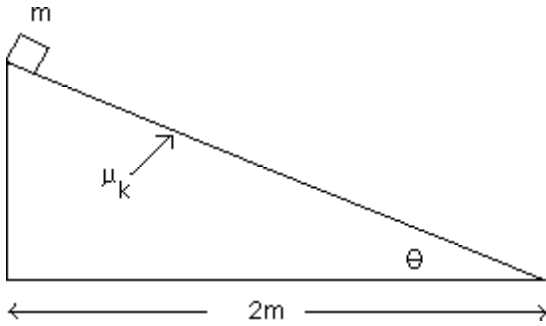

- a) The potential energy at the top
- b) the work done by friction on the mass on the way down.
- c) the kinetic energy and the velocity of the mass at the bottom.
- d) if there had not been friction what velocity would the mass have at bottom.

ans: a) 11.27 J b) 3.9 J c) 7.37 J and 3.84 m/s
d) 4.75 m/s

5) A 0.5 kg mass moving at a constant velocity enters a 3m surface with friction. After passing through this, it slides up the frictionless incline to a certain height where it comes to rest then turns around. Find

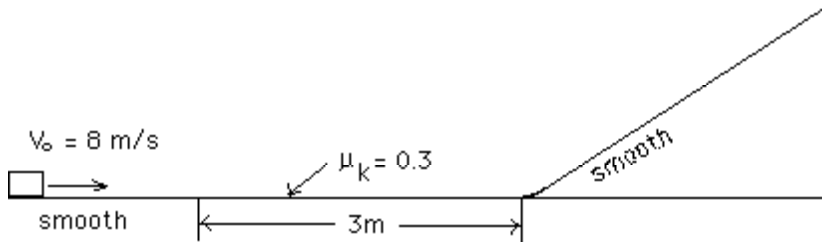

- a) the kinetic energy of the mass before it enters the friction area.
- b) the work done against the mass by friction as it passes through the rough area
- c) the kinetic energy and velocity of the mass at the incline base just before sliding up hill.

- d) the max height the mass achieves before turning around.
- e) show how the answer in part d) can be found if the mass were not known.

ans: a) 16 J b) 4.41 J c) 11.59 J, 6.81 m/s d) 2.36 m

6) As shown a mass of $m = 0.75 \text{ kg}$ is launched off a table, $\mu_k = 0.56$, by a spring. The mass was initially compressed against the spring a distance of $x = 0.45 \text{ m}$. The mass hits the ground with a velocity of $V = 8 \text{ m/s}$. ANSWER THE FOLLOWING QUESTIONS USING CONSERVATION OF ENERGY

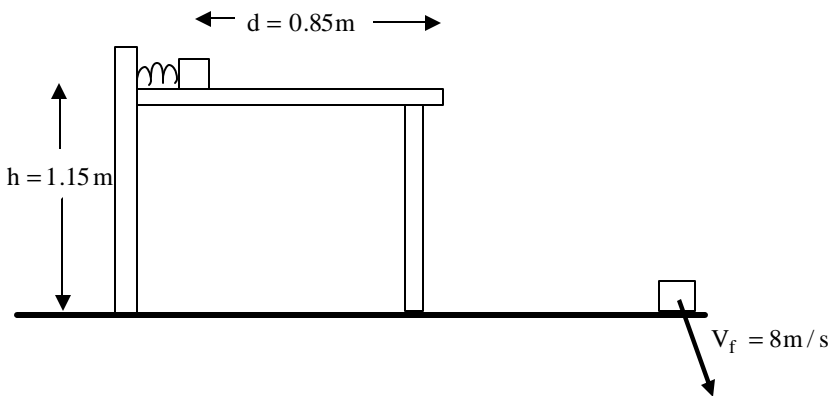

- a) what velocity did it have just as it slid off the table.
- b) What angle does the final velocity vector make with the ground.
- c) what was the work done by friction as it slid across the table. (Hint : $F = ma$)
- d) what is the value of the spring constant

e) what was the acceleration of the mass as

Ans: a) 6.44 m/s b) 36.4 deg. c) 3.5 joules d) 188.2 N/m e) 5.49 m/s²

7) A mass hanging by a cord is given an initial horizontal velocity V_0 as shown. The mass swings up and strikes the wall as shown with V_f . Find :

$L = 1\text{ m}$, $V_0 = 6\text{ m/s}$

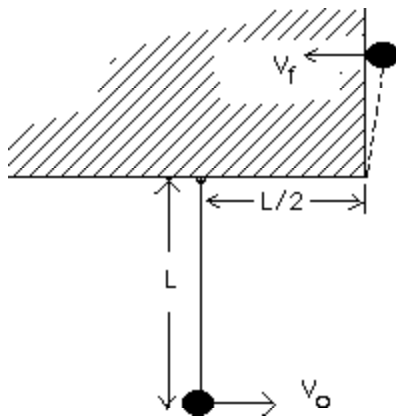

A) the velocity that the mass impacts the wall with.
ans : $V_f = 2.57\text{ m/s}$

8) A compressed spring of $k = 50\text{ N/m}$ launches a 0.75 kg mass connected to a cord of $L = 1.2\text{ m}$ long. The mass swings up as shown. The velocity of the mass at the apex of its flight is 4 m/s .

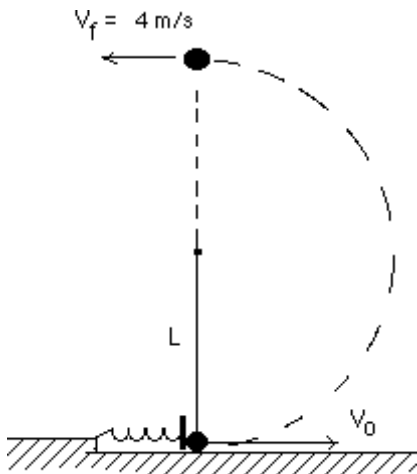

- a) (5 pts) find the initial compression distance “ X_c “ of the spring .
- b) (3 pts) determine the initial velocity V_0 of the mass just upon leaving the spring
- c) (2 pts) What force did the spring exert on the mass when compressed by X_c found above.

Ans: a) 0.97 m b) 7.92 m/s c) 48.5 N

Fig 1

9) As shown $m_1 = 1\text{ kg}$ and $m_2 = 2\text{ kg}$ are connected by a cord that wraps around an ideal pulley. M_2 is released from rest and falls to the ground.

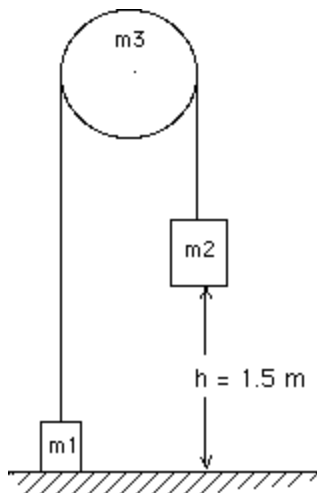

- a) determine the acceleration of the masses and the tensions in the cord.
- b) **use conservation of energy** to determine the velocity of m_2 on impact with the floor . (You must consider the energy of both masses when applying conservation of energy)

ans: a) 3.27 m/s^2 b) 3.13 m/s

10) If m_2 is released from rest, find the velocity it hits the floor with using

CONSERVATION OF ENERGY.

$m_1 = 1.2 \text{ kg}$, $m_2 = 4 \text{ kg}$ and $\mu_k = 0.32$

ans: $v = 2.83 \text{ m/s}$

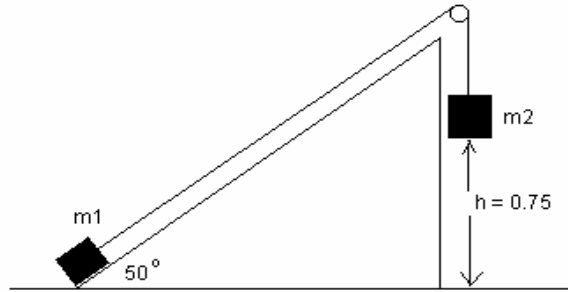

11) A 0.5 kg model rocket is launched into the air from rest. The engine pushes up on the rocket with a constant force of 12 N up to a height of 100 m at which point the engine runs out of fuel. The work done against the rocket by air friction up to this 100m is 200 Joules.

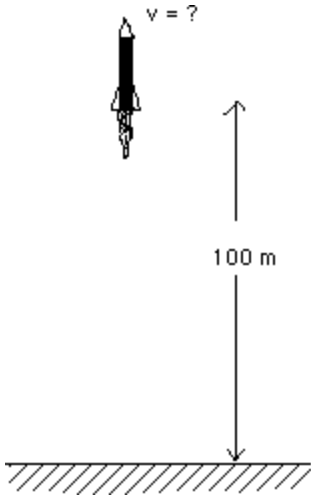

- a) What is the net work done on the rocket up to the 100m mark.
- b) how fast is the rocket moving at the 100 m mark .
- c) what is the Ave. force of air friction on the rocket during its climb to 100 meters.
 - 1) The rocket reaches a max height of 200 meters then falls back toward the ground. At some point, on its way down, it reaches a terminal velocity of 30 m/s .
 - 1) what was the net work done on the rocket as it fell to terminal velocity.
 - 2) what net work is done on the rocket during the final fall to Earth.

ans: a) 510 J b) 45.17 m/s c) 2 N d) 225 J

12) As shown a 1 kg mass moving at constant velocity slides up a hill then onto a flat surface with friction. Find:

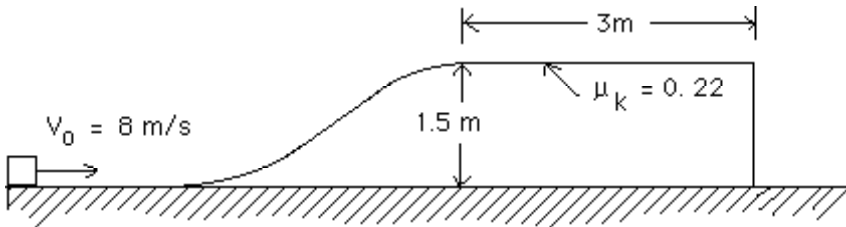

- a) the kinetic energy and velocity of the mass at the hill top just before entering the friction area.
- b) find the work done by friction on the mass through the friction area.
- c) where does the mass land relative the base of the hill.
- d) what is velocity of mass on impact with ground and show how this can be found if the mass were not known.

ans: a) 17.3 J , 5.88 m/s b) neg. 6.47 J c) 2.57 m d) 7.14 m/s

13) A 0.250 kg mass is shot by a spring across a 1.5 m surface with friction into a frictionless circular loop. Here it circles around and finally lands at point "b". The normal force exerted on the mass by the track at point "a" is known to be 3.61 N. The radius of the loop is $R = 20$ cm. and the spring constant $k = 45$ N/m

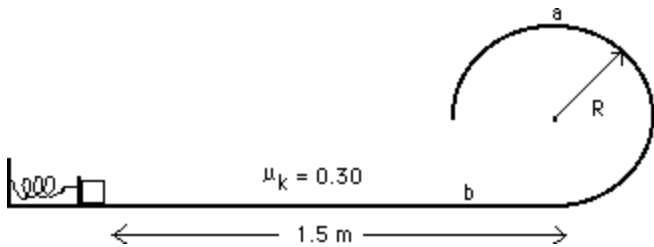

- what K.E. and velocity, did the mass have at the top of the loop.
- what K.E. and velocity, did the mass have upon entering the loop
- what work did friction do on the mass as it slid across the 1.5 m surface?
- what work did the spring perform on the mass that

resulted in the above conditions?

- how far was the spring initially compressed.
- what velocity does it land at point "b" with?

a) 0.606J , 2.2 m/s , b) 1.5842 J , 3.56 m/s c) - 1.1 J d) 2.68 J e) 0.345 m f) ?????

14) A roller coaster designed for a major law suit has a section taken out at the top of the second arc of the track such that the car just barely makes it to the other side. If the radius of curvature, R , is 6 m find :

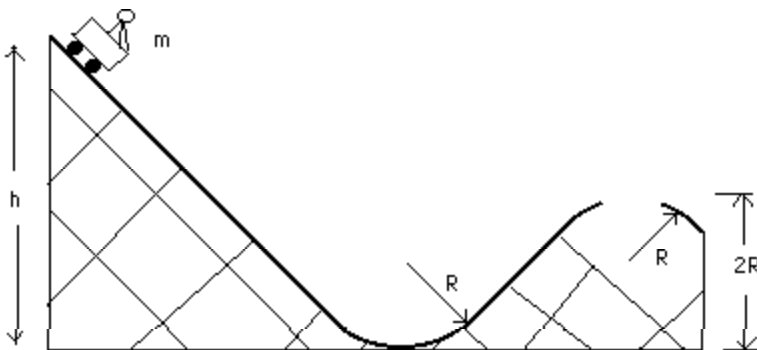

- the velocity of the car at the top of the upper arc and at the bottom of the lower arc. (no you dont need the mass for part a) or b))
- if the car is released from rest, the minimum height "h" that will result in the condition above.
- if the mass of the car plus rider is 500 kg find the minimum force the bottom of the arc must be able to support.

ans: a) 7.7 m/s , 17.15 m/s b) 15 m c) 29,410 N

15) Below is a pendulum resting on an incline. The mass "m" is tied to a thread "L" long and free to swing across the surface of the incline. Assume the mass is shaped like a hockey puck. There exists kinetic friction between the mass and the incline surface. ($\theta = 60^\circ$, $L = 0.84m$, $\mu_k = 0.32$, $m = 0.15$ kg)

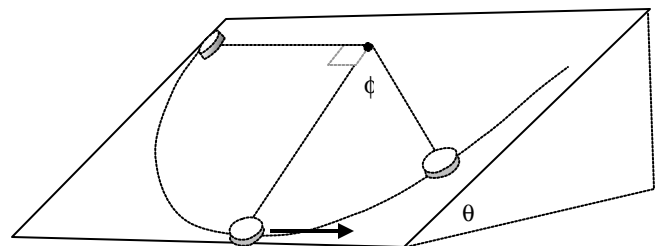

- find the velocity of the mass at the bottom of its swing.(3.18 m/s)
- The mass stops at the angle ϕ shown below. Determine the value of ϕ . (60.7°)

16) A mass on a string of $L = 1.2\text{m}$ is released from rest as shown. It swings down and the string catches the peg protruding out of the wall mounted $\frac{2}{3}L$ directly below the pivot. Find the velocity of the mass at the points A and B. (3.09 m/s and 1.32 m/s)

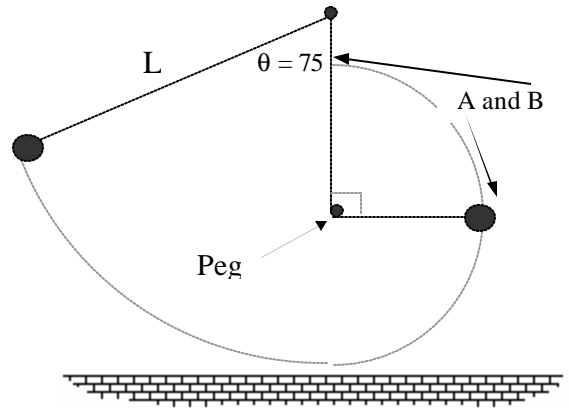

17) A mass connected to an unstretched spring is released from rest on an incline with friction. The velocity at the bottom is $v = 2.6\text{ m/s}$. ($m = 0.25\text{ kg}$, $\mu_k = 0.15$)

a) find the spring constant ($k = 1.43\text{ N/m}$)

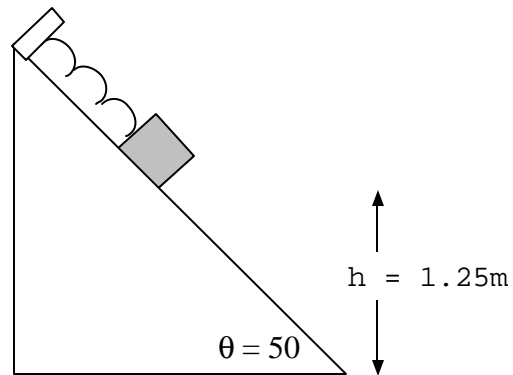

18) A mass is released from rest on top of an incline with friction. It collides with the spring at the bottom. How far will it compress the spring before stopping. ($x = 0.172\text{ m}$)

$m = 0.3\text{ kg}$, $k = 200\text{ N/m}$, $\mu_k = 0.18$

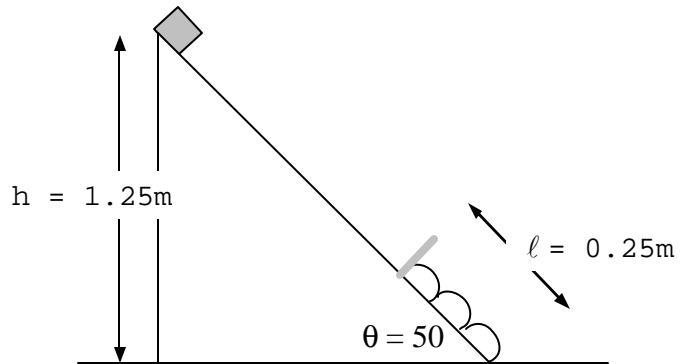

19) A mass of 1.8 kg on a string of L is released from rest as shown. Find the tension in the cord at the point when the mass is $\frac{1}{4}L$ from ground. ($T = 39.7\text{ N}$)

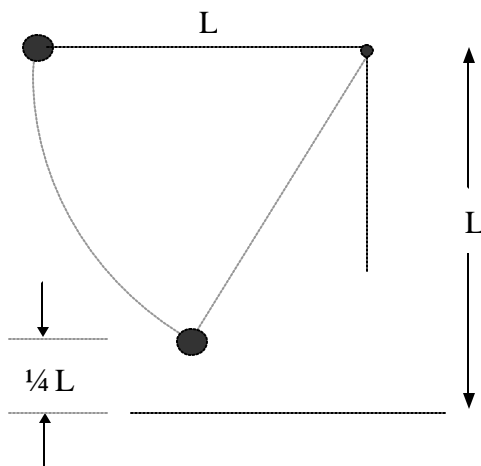

20) A new kind of bungee jump uses a spring. The mass is connected to the spring of un-stretched length ℓ_o and released from rest h above the ground. The mass swings down stretching the spring and then back up in a semi-circular path. Find minimum k such that mass does not hit ground. $m = 50 \text{ kg}$ ($k = 44.1 \text{ N/m}$)

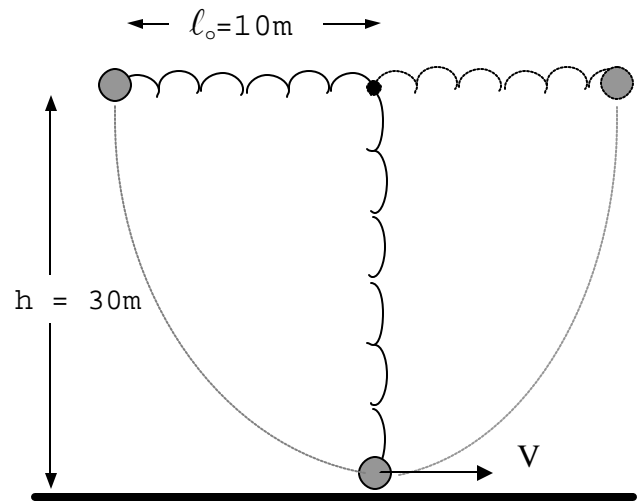

21) A bullet of mass $m = 0.015 \text{ kg}$ is fired into a block of clay at an initial velocity of V_o and **comes to rest** at $d = 0.6\text{m}$ inside the block as shown. The frictional force exerted on the bullet by the clay is given as $F = -F_o e^{-(3x)}$ where $F_o = 20,000 \text{ N}$ and x is the distance the bullet has traveled.

Use the definition of work and the **work energy theorem** to determine the value of the initial velocity.

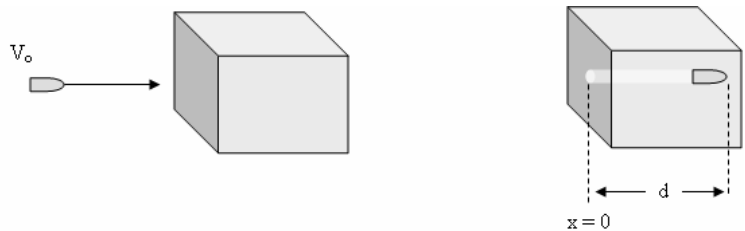

ans: 861.37 m/s

22) The potential energy function associated with quarks in a nucleon is estimated to behave like

$U = -\frac{D e^{r/r_o}}{r}$ where D is a constant $= 1 \times 10^{-27} \text{ Jm}$ and $r_o = 2 \times 10^{-15} \text{ m}$, and is called the nuclear edge. For distances greater than this, between two nucleons, the strong force is not active. Estimate the force between quarks if $r = 5 \times 10^{-17} \text{ m}$. (estimated average distance between quarks) .

23) A 0.25 kg mass is launched by a rubber band as shown. The mass travels across the friction area and then up the hill to some max height. No friction on the hill. The force of the rubber band depends on how far it's stretched. The equation that gives the force as a function of x stretch is $F = 6\sqrt{x}$ where 6 is a constant with units of $\frac{\text{N}}{\text{m}^{1/2}}$. The rubber band is stretched 0.6 m the released.

a) find the velocity of the mass just before entering the friction area.
ans(3.86 m/s)

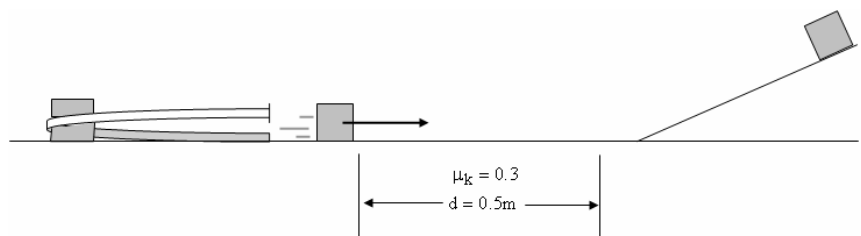

b) find the max height acquired by the mass. ans($h = 0.61 \text{ m}$)

